

CIVIL ENGINEERING

Open Channel Flow



Comprehensive Theory
with Solved Examples and Practice Questions





MADE EASY Publications Pvt. Ltd.

Corporate Office: 44-A/4, Kalu Sarai (Near Hauz Khas Metro Station), New Delhi-110016 | **Ph. :** 9021300500

Email : infomep@madeeasy.in | **Web :** www.madeeasypublications.org

Open Channel Flow

Copyright © by MADE EASY Publications Pvt. Ltd.
All rights are reserved. No part of this publication may be reproduced, stored in or introduced into a retrieval system, or transmitted in any form or by any means (electronic, mechanical, photo-copying, recording or otherwise), without the prior written permission of the above mentioned publisher of this book.



MADE EASY Publications Pvt. Ltd. has taken due care in collecting the data and providing the solutions, before publishing this book. In spite of this, if any inaccuracy or printing error occurs then **MADE EASY Publications Pvt. Ltd.** owes no responsibility. We will be grateful if you could point out any such error. Your suggestions will be appreciated.

EDITIONS

First Edition : 2023

Second Edition : 2024

Third Edition : 2025

Fourth Edition : 2026

CONTENTS

Open Channel Flow

CHAPTER 1

Introduction 1-16

1.1	Introduction	1
1.2	Open Channel Flow and Pipe Flow	1
1.3	Classifications of Channels.....	2
1.4	Classifications of Flows	3
1.5	Velocity Distribution.....	6
1.6	Pressure Distribution.....	8
1.7	Pressure Distribution in Curvilinear Flow	9
1.8	Continuity Equation	9
1.9	Energy Equation.....	10
1.10	Momentum Equation.....	11
1.11	Specific Force	12
	<i>Objective Brain Teasers</i>	14
	<i>Conventional Brain Teasers</i>	15

CHAPTER 2

Uniform Flow 17-40

2.1	Introduction	17
2.2	Velocity Measurements.....	18
2.3	Most Economical or Most Efficient Section of Channel.....	22
2.4	Types of Channel based on efficient channel	35

Objective Brain Teasers.....36

Conventional Brain Teasers.....39

CHAPTER 3

Energy Depth Relationship 41-74

3.1	Introduction	41
3.2	Specific Energy	42
3.3	Specific Force	46
3.4	Calculation of the Critical Depth.....	49
3.5	Section Factor (Z) for Critical Flow Computation.....	53
3.6	Channel Transition	54
3.7	Metering Flumes.....	65
	<i>Objective Brain Teasers</i>	69
	<i>Conventional Brain Teasers</i>	72

CHAPTER 4

Gradually Varied Flow..... 75-100

4.1	Introduction	75
4.2	Assumptions in Gradually Varied Flow	75
4.3	Differential Equation for Gradually Varied Flow	76
4.4	Liquid Surface Profiles in Open Channels.....	81
4.5	Control Section.....	88
4.6	Break in Grade.....	89
4.7	Gradually Varied Flow Computation	91
	<i>Objective Brain Teasers</i>	95
	<i>Conventional Brain Teasers</i>	98

CHAPTER 5**Rapidly Varied flow: Hydraulic Jump... 101-123**

5.1	Introduction	101
5.2	Hydraulic Jump	101
5.3	Applications of Hydraulic Jump	102
5.4	Sequent Depth or Conjugate Depth	102
5.5	Specific Forces for Rectangular Channel.....	102
5.6	Hydraulic Jump in Horizontal Rectangular Channel ..	103
5.7	Jump on Non-rectangular Horizontal channel.....	112
5.8	Hydraulic Jump on the Sloping Floor.....	113
5.9	Velocity profile for Hydraulic jump	114

5.10	Classification of Hydraulic Jumps	114
	<i>Objective Brain Teasers</i>	118
	<i>Conventional Brain Teasers</i>	121

CHAPTER 6**Unsteady flow : Surges..... 124-133**

6.1	Introduction	124
6.2	Surges in Open Channels	124
6.3	Analysis of Surges.....	125
	<i>Objective Brain Teasers</i>	131
	<i>Conventional Brain Teasers</i>	131



Introduction

1.1 INTRODUCTION

- Flow occurring in a natural or a man made structure with a free surface [i.e. at atmospheric pressure] is called **Open Channel Flow**.
- The free surface is an interface between the moving liquid and an overlying fluid medium (air) and will have constant pressure (i.e. atmospheric pressure).
- For example, flow in rivers, streams, flow in sanitary and storm sewer flowing partially full are open channel flows.
- Flow in pipes is driven by gravity and/or a pressure difference, whereas flow in a channel is driven naturally by gravity.
- Surface tension and compressibility effects are neglected in analysis of open channel flow.
- In open channel flow, the Hydraulic Gradient Line (HGL) coincides with the free surface.
- In this chapter, the basic principles of open-channel flows and the associated correlations for steady one-dimensional flow in channels of common cross sections are discussed.

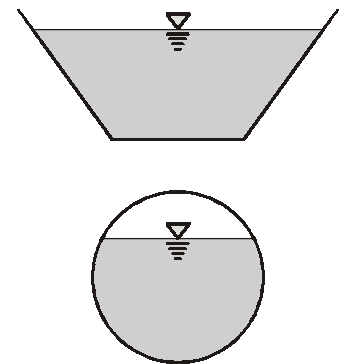

Fig: Open Channel Flow

1.2 OPEN CHANNEL FLOW AND PIPE FLOW

- Liquids are transferred between two locations with the help of conduits in which the flow can be either pipe flow or open channel flow.
- If the flow has a free surface, as in case of rivers or canals, then it is known as open channel flow. On the other hand, if the conduit is closed from all the sides and flows to full depth, then it is known as pipe flow.

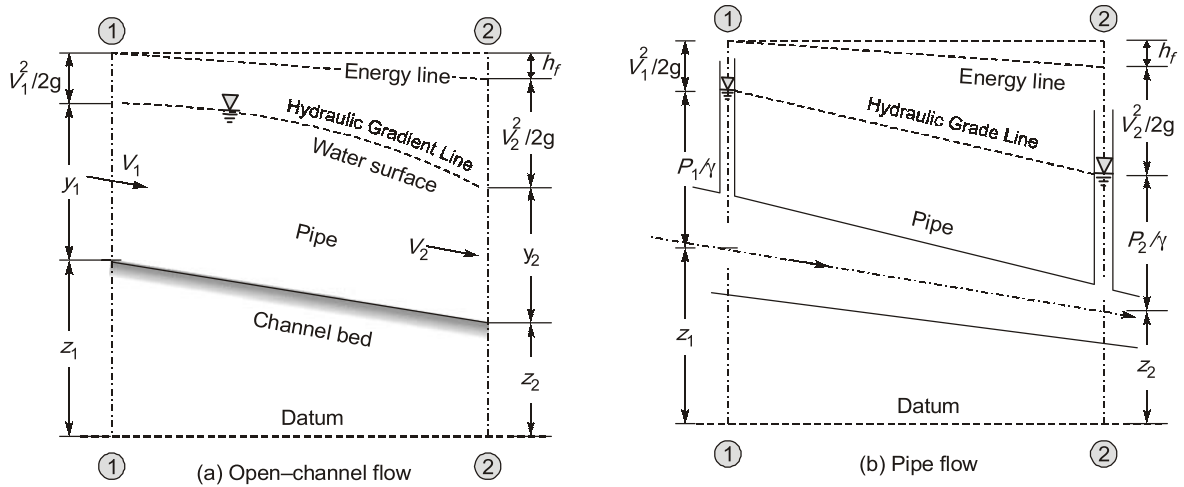

Fig: Schematic representation of open-channel flow and pipe flow

Table : Open Channel Flow vs Pipe Flow

S.No.	Open Channel Flow	Pipe Flow
1.	Depth of flow can vary both in time and along the channel depending upon the nature of flow. Therefore cross-section area is variable.	Flow occurs in a pre fixed cross-section.
2.	It is essential in case of open channel that the liquid should have a free surface.	There is no free surface of liquid. Pipe always run full.
3.	Flow occurs due to gravity i.e. potential energy gradient.	Flow occurs due to energy gradient.
4.	Hydraulic grade line coincides with the free surface.	Hydraulic grade line can be above or below the pipe axis.
5.	Froude number (representing influence of gravity) is the prime non-dimensional number governing the flow.	Reynolds number (representing influence of fluid viscosity) is the prime non-dimensional number governing the flow.

1.3 CLASSIFICATIONS OF CHANNELS

1.3.1 Prismatic and Non-prismatic Channels

- A channel in which the cross-sectional shape, size and the bottom slope are constant is termed as a prismatic channel.
- Man-made channels are prismatic over long stretches. These can be rectangular, trapezoidal, triangular or circular.
- A channel in which any of the above three conditions are not satisfied is known as non-prismatic channel.

Example: Natural Channels

1.3.2 Rigid and Mobile Boundary Channels

- Rigid channels are those in which the boundary is not deformable. The shape, planiform and roughness magnitudes are not functions of the flow parameters.

Example: Lined canals, Sewers etc.

- The rigid channels are considered to have only one degree of freedom i.e., only depth can change with space and time.
- In case of mobile boundary channels, erosion and silting take place simultaneously due to flow. Boundaries of these channels undergo deformation due to continuous process of erosion and deposition.
- A mobile-boundary channel has four-degrees of freedom, i.e., depth, slope, width and planiform.



In open channel flow, we study only rigid boundary channel.

1.4 CLASSIFICATIONS OF FLOWS

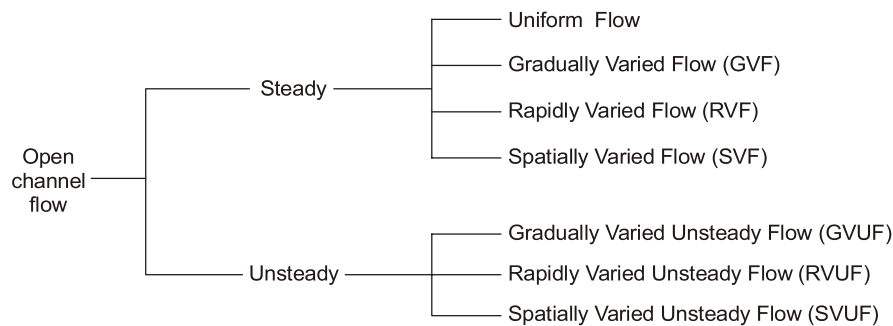

Fig: Classifications of Flow

1.4.1 Steady and Unsteady Flow

- If in a channel flow, the depth and other flow characteristics at a section do not changes with time, then the flow will be known as steady flow.
- If the flow characteristics do changes with time, then the flow is termed as unsteady flow.
- Analysis of unsteady flow is very tedious and the depth of flow changes continuously due to wind blow, surface tension etc. So, to make it easy, a time average of the depth is taken at the section.
- Flow of flood in rivers and rapidly varying surges in canals are some examples of unsteady flows.

1.4.2 Uniform and Non-uniform Flow

- If the flow properties, say the depth of flow and discharge, remain constant along the length of the channel, then the flow is said to be uniform flow.
- Uniform flow conditions occur in long straight channel with constant slope and constant cross-section.
- A flow in which the flow properties vary along the length of the channel is known as non-uniform flow.
- A prismatic channel carrying a certain discharge with a constant velocity is an example of uniform flow.

- Flow in non-prismatic channel and flow with varying velocities in a prismatic channel are examples of non-uniform flow.
- Unsteady uniform flow is not possible and hence the term uniform flow is used for steady uniform flow. On the other hand, a non-uniform flow can either be steady or unsteady.



- **Normal depth (y_n)** : The flow depth in uniform channel is known as normal depth.
- Under uniform flow : Bed slope = Energy line slope = Water surface slope

1.4.3 Gradually-varied and Rapidly-varied Flow

- If the change of depth in a varied flow is gradual so that the curvature of streamlines is not excessive, such a flow is known as Gradually-Variied Flow (GVF).
- In Gradually-Variied Flow (GVF), the loss of energy is mainly due to boundary friction and the pressure distribution in vertical direction is taken as hydrostatic.
Example: Backing up of water in a stream due to a dam.
- If the curvature in a varied flow is large and the depth changes appreciably over short length, such a phenomenon is termed as Rapidly-Variied Flow (RVF).
Example: Hydraulic jump
- Gradually-Variied Flow (GVF) and Rapidly-Variied Flow (RVF) both can further be classified as steady and unsteady flow. Example of each conditions are as follows:
 - Gradually varied unsteady flow** : Passage of flood wave in a river.
 - Gradually varied steady flow** : Backing up of water in a stream due to dam.
 - Rapidly varied unsteady flow** : A surge moving up a canal breaking of wave on the shore.
 - Rapidly varied steady flow** : A hydraulic jump below a spillway or a sluice gate.

1.4.4 Spatially-Variied Flow

- If some flow is added to or abstracted from the system, then the resulting varied flow is known as Spatially Variied Flow (SVF).
- Spatially Variied Flow (SVF) can be steady or unsteady. The flow over a side weir, flow over a bottom rack is Spatially Variied steady Flow (SVF) whereas surface runoff due to rainfall is an Spatially Variied unsteady Flow (SVF).

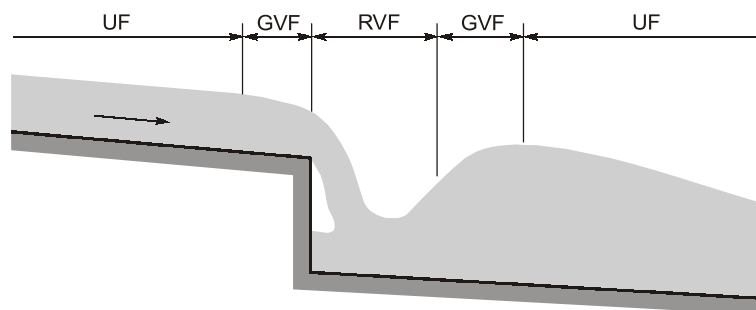

Fig. Flow in an Open Channel

1.4.5 Laminar and Turbulent Flow

- Open channel flow can be laminar, transitional, or turbulent, depending on the value of the Reynolds number which is a dimensionless number and is expressed as,

$$R_e = \frac{\rho V R_h}{\mu} = \frac{V R_h}{\nu}$$

where, $R_h =$ Hydraulic radius $= \frac{A_c}{P}$, $V =$ Average flow velocity

$A_c =$ Flow area of channel, $P =$ Wetted perimeter of channel

- Since, Hydraulic diameter (D_h) $= \frac{4A_c}{P} = 4R_h$
- Therefore, Reynolds number based on hydraulic radius is one-fourth of the Reynolds number based on hydraulic diameter.

$$R_e \leq 500 \Rightarrow \text{Laminar flow}$$

$$500 < R_e \leq 2500 \Rightarrow \text{Transitional flow}$$

$$2500 < R_e \Rightarrow \text{Turbulent flow}$$

- Generally, Reynolds number in open channel is above 50,000 and thus the flow is almost always turbulent.

1.4.6 Subcritical, Critical and Supercritical Flows

- In open channel, flow is under the influence of gravity therefore gravity force plays an important role, hence Froude number is predominant.
- Depending on the relative effect of gravity and inertia forces, the flow may be designated as subcritical, critical or super critical flow.

Since, Froude Number (F_r) $= \frac{V}{\sqrt{gD}} = \sqrt{\frac{\text{Inertia force}}{\text{Gravity force}}}$

Where, $D =$ Hydraulic depth $= \frac{A}{T}$; $T =$ Top width of the channel

- If,
- $F_r < 1$: Subcritical flow or tranquil flow
 - $F_r = 1$: Critical flow
 - $F_r > 1$: Supercritical flow or torrential flow

- At critical flow condition, depth of flow is called critical depth (y_c) and velocity of flow is called critical velocity (V_c) and Froude number is equal to unity (1).
- Denominator of Froude number (\sqrt{gD}) represents the speed at which the disturbance wave travels in still water condition, and is known as Celerity, C .

- At low flow velocity i.e. $F_r < 1$, a small disturbance produced in the stream will travel in upstream direction with a velocity of $(C - V)$ and in downstream direction with a velocity of $(C + V)$ with respect to stationary observer on the ground, where $C = \text{Celerity } (\sqrt{gD})$ and $V = \text{average velocity of stream}$.
- At high flow velocity i.e. $F_r > 1$, disturbance cannot travel upstream as the celerity is less than velocity V . Thus, the disturbance wave is washed downstream with velocity equal to $(V - C)$ with respect to stationary observer on ground.
- Therefore, in supercritical flow disturbance wave does not travel in upstream direction and in subcritical flow it can travel in both upstream and downstream direction.
- This property of travel of disturbance wave can be used in the field to determine whether the flow is subcritical or super critical.
- In case of critical flow i.e. $F_r = 1$, Celerity, C is equal to velocity V i.e. velocity of travel wave $|V - C| = 0$. Hence, the disturbance wave will not travel at all.
- A surface wave is swept downstream when $F_r > 1$ and appears frozen on the surface when $F_r = 1$.

1.5 VELOCITY DISTRIBUTION

- In an open channel, velocity across any section is not constant. It is zero at the channel boundary and maximum at certain depth below the surface due to the production of secondary current which is a function of aspect ratio (d/B).
- The contours of equal velocity are called **Isovels**.
- The dip of the maximum velocity point depends on aspect ratio (depth to width) of the channel.
- For a deep narrow channel, the location of maximum velocity point will be much lower than the wider channel with the same depth.
- For rivers and canals, average velocity attains at a depth of $0.6 y_0$ below the free surface, where, y_0 is the depth of flow.
- Also, average velocity can be represented as (two-point problem)

$$V_{\text{avg}} = \frac{V_{0.2} + V_{0.8}}{2}$$

where,

$V_{0.2} = \text{Velocity at a depth of } 0.2 y_0 \text{ from the free surface}$

$V_{0.8} = \text{Velocity at a depth of } 0.8 y_0 \text{ from the free surface}$

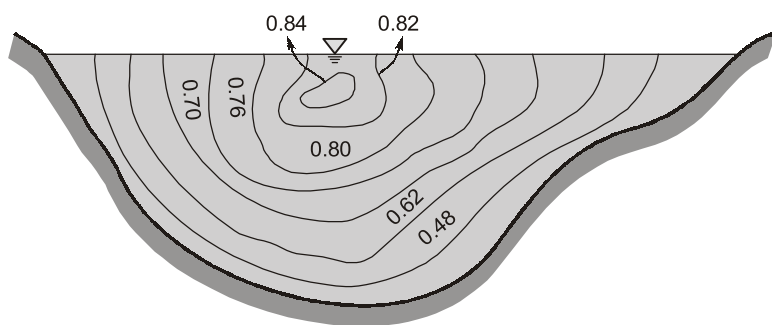

(a) Natural Channel



OBJECTIVE BRAIN TEASERS

- Q.1** One-dimensional method of flow analysis means
- uniform flow
 - Steady uniform flow
 - neglecting the variations in the transverse directions
 - neglecting the variations in the longitudinal direction

- Q.2** Some example of steady spatially varied flow are
- Flow in canal
 - Surge
 - Hydraulic jump
 - Flow over side weir

[MSQ]

- Q.3** Which of the following statements for rigid and mobile boundary channels is/are CORRECT ?
- In rigid boundary channels, the shape and roughness factor is not a function of flow parameter.
 - In rigid boundary channels only depth of flow may vary with space and time depending on the nature of flow.
 - In mobile boundary channels, only depth and bed slope changes with space and time.
 - The degree of freedom for rigid and mobile boundary channels are 1 and 4 respectively.

[MSQ]

- Q.4** A steady flow occurs in an open channel with lateral inflow of $q \text{ m}^3/\text{s}$ per unit width as shown in the figure. The mass conservation equation is

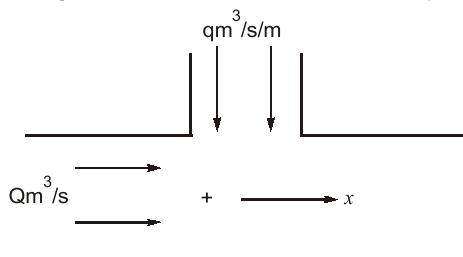

$$(a) \frac{\partial q}{\partial x} = 0$$

$$(b) \frac{\partial Q}{\partial x} = 0$$

$$(c) \frac{\partial Q}{\partial x} - q = 0$$

$$(d) \frac{\partial Q}{\partial x} + q = 0$$

- Q.5** A person standing on the bank of a canal drops a stone on the water surface. He notices that the disturbance on the water surface is not traveling upstream. This is because the flow in the canal is
- sub-critical
 - super-critical
 - steady
 - uniform

ANSWERS KEY

- (c)
- (c, d)
- (a, b, c)
- (c)
- (b)

HINTS & EXPLANATIONS

- 3. (a, b, d)**

In rigid boundary channel, only depth of flow may vary with space and time depending on nature of flow. In mobile boundary channels, depth, bed width, bed slope and layout changes with space and time.





CONVENTIONAL BRAIN TEASERS

Q.1 A sluice gate in a 2.0 m wide horizontal rectangular channel is discharging water freely as shown in figure. If the depths at a small distance upstream (y_1) and downstream (y_2) are 2.5 m and 0.20 m respectively, estimate the discharge in the channel (i) by neglecting energy losses at the gate and (ii) by assuming the energy loss at the gate to be 10% of the upstream depth y_1 .

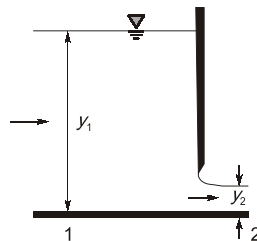

Solution :

Given, $y_1 = 2.5 \text{ m}$ and $y_2 = 0.20 \text{ m}$

$$\therefore Q = By_1V_1 = By_2V_2$$

$$\Rightarrow V_2 = \frac{y_1}{y_2} \times V_1 = \frac{2.5}{0.20} \times V_1 = 12.5V_1$$

(i) When there is no energy loss

$$Z_1 + y_1 + \frac{V_1^2}{2g} = Z_2 + y_2 + \frac{V_2^2}{2g}$$

Since the channel is horizontal, so $Z_1 = Z_2$ and thus

$$\frac{V_2^2}{2g} - \frac{V_1^2}{2g} = (y_1 - y_2)$$

$$\Rightarrow \frac{V_1^2}{2g} [(12.5)^2 - 1] = 2.50 - 0.20 = 2.30$$

$$\Rightarrow \frac{V_1^2}{2g} = \frac{2.30}{155.25} = 0.01481 \Rightarrow V_1 = 0.539 \text{ m/s}$$

$$\therefore \text{Discharge, } Q = By_1V_1 = 2.0 \times 2.5 \times 0.539 = 2.695 \text{ m}^3/\text{s}$$